

doi: 10.32620/oikit.2023.99.02

УДК 629.7.01

Sun Yifang, O. G. Grebenikov, O. O. Vendin

The effect of cold extruded annular grooves on the fatigue life of wing panels with functional holes

National Aerospace University "Kharkiv Aviation Institute", 61070 Kharkiv, Ukraine.

This article studies in detail the method of cold extrusion annular grooves to solve the problem of aircraft fatigue life extension that reduces the fatigue life of aircraft wing panels due to functional holes. This method is a very simple and effective anti-fatigue manufacturing technology. In order to simulate the different wing panels with functional holes, the experiment is designed to extrude the specimen with different extrusion forces to obtain annular grooves of different depths. Fatigue tests are conducted on specimens with annular grooves. The test results show that: 1) Cold extrusion annular grooves can extend the fatigue life of wing panels with functional holes; 2) The fatigue life of wing panels with functional holes is affected by the depth of the cold extrusion annular groove. The fatigue life changes in an inverted "V" shape as the depth of the cold extrusion annular groove increases; 3) When cold extrusion annular groove depth is 0.26mm, the fatigue life of specimen with holes is maximum, and the fatigue life is increased by 2.35~32.9 times when specimen thickness is 5 mm.

Keywords: wing panel; functional hole; cold extrusion; annular groove; experiment; fatigue life.

1. Test specimen

In order to obtain more load space, modern aircraft usually adopt a compact structural layout. Since there are many structural components on the aircraft, in order to ensure the reasonable installation of each structure and efficient use of space, it is necessary to create some functional holes. For example, in modern transport aircraft, almost all fuel is stored in the wings. The requirements for reliable operation of the fuel system do not always coincide with the "interests" of wing design. In order to ensure the normal supply of aircraft fuel, some functional holes must be made in the panels of wings. However, the cutouts and functional holes in the stretched wing panels will inevitably lead to damage to the structural fatigue life of the aircraft wing. Figure 1 shows part of an aircraft frame structure with functional holes [1].

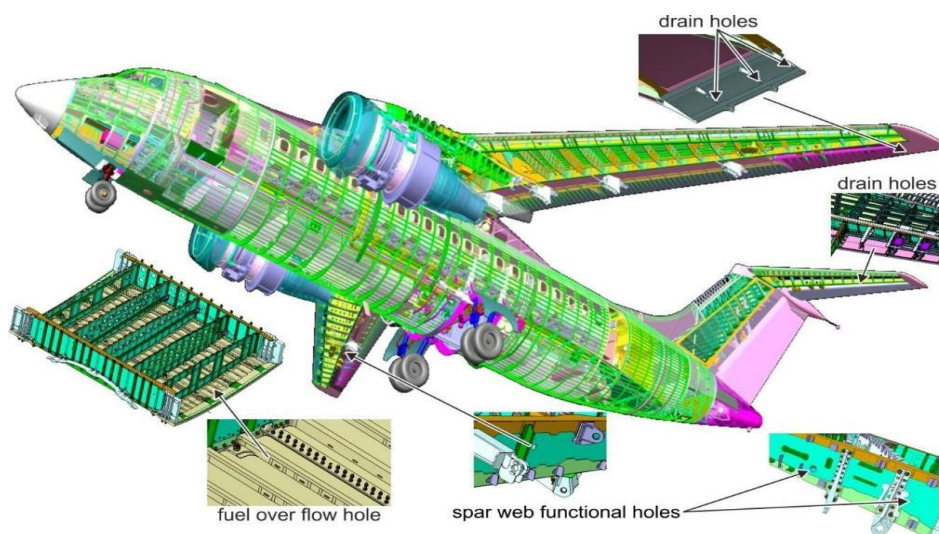

Fig. 1. Aircraft frame structure with functional holes

A large number of studies have shown that the residual stress field generated by the cold extrusion strengthening process can effectively reduce the tensile stress caused by external loads, improve fatigue strength, and effectively reduce the stress intensity factor at the crack tip, which will slow down the expansion rate of fatigue cracks and significantly improve the fatigue life of the connector [2-3]. For aircraft wing panels, Kiva et al. [4] proposed a method to extend the fatigue life of components with holes through cold extrusion arc grooves, and verified it through experiments. The fatigue life of the strengthened specimen can be increased by more than 3.5 times. Sun et al. [5] deeply explored the impact of the depth and angle of cold extrusion arc grooves on the improvement of component life. For specimens made of material D16T, the best fatigue life can be obtained by extruding a 0.3 mm deep, 120° arc-shaped groove.

This article draws on the research methods of Kiva, Sun and others to propose a method of cold extrusion annular groove to improve the fatigue life of panels with functional holes. This method is to make an annular groove on the edge of the hole in the component through cold extrusion, so that plastic deformation occurs around the hole and thereby generates residual stress. This residual stress can offset the tension of the component. Or the stress damage generated during pressing can achieve the purpose of extending the life of the component. In order to verify the correctness of the method of cold extrusion annular groove improving the life of panels with functional holes, the following test was carried out for verification.

The specific parameters of the test specimen are shown in Figure 2, and the actual object is shown in Figure 3.

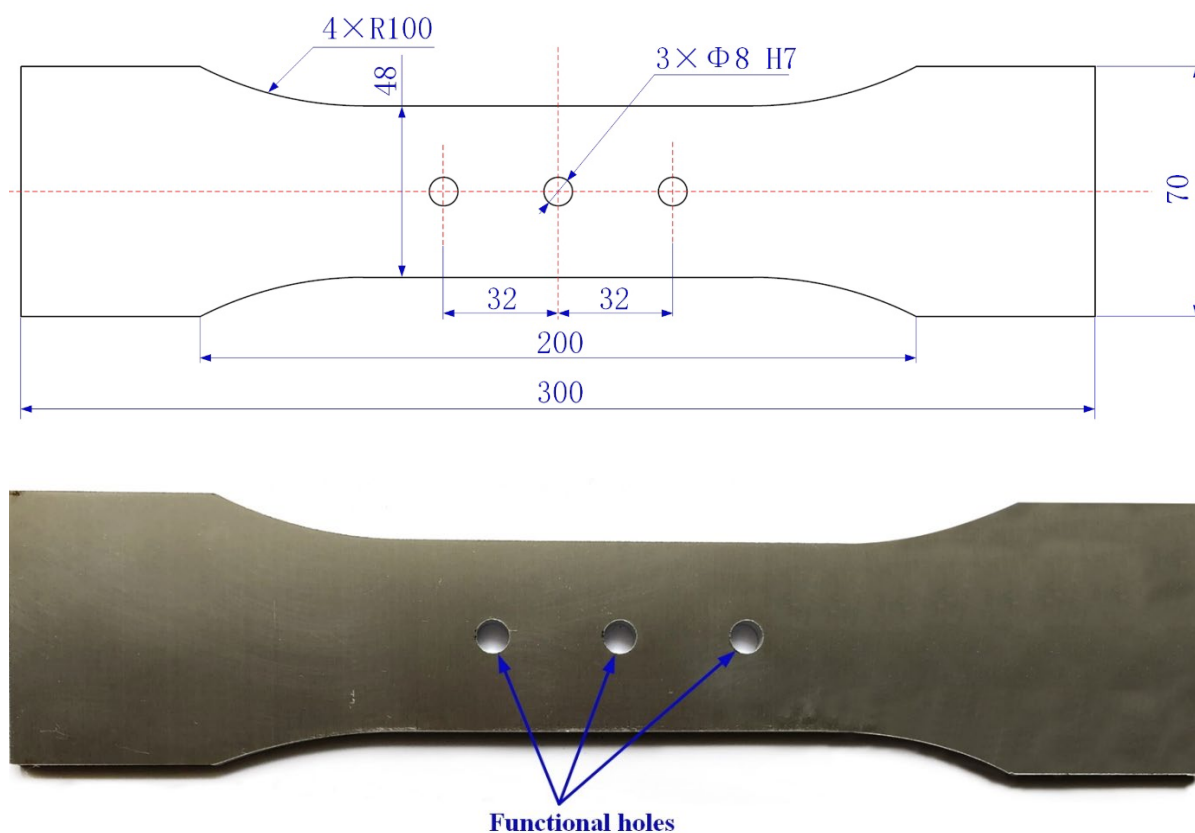

Fig. 2. Specimen

The three holes in the middle of the specimen are simulated functional holes. The total length of the specimen is 300 mm, the center width is 48 mm, and the thickness is 5mm. The functional hole is located on the central axis of the specimen, with a hole diameter of 8 mm. The center distance between holes is 32 mm, and the tolerance level of functional holes is H7.

The test specimen is made of 6061 aluminum alloy plate. The main performance parameters of 6061-T6 aluminum alloy are shown in Table 1. 6061 aluminum alloy is one of the most popular duralumin alloys in the shipbuilding, aviation and aerospace industries. It has good formability, weldability and machinability, and is widely used in the production of aircraft skins, fuselage frames, beams, rotors, propellers, fuel tanks, wall panels and landing gear struts, as well as rocket forging rings, spacecraft Spaceship siding, etc.

Table 1

The main parameters of materials

Materials	Density	Young's Modulus	Ultimate Strength	Yield Strength	Poisson's Ratio
6061-T6	2700 (kg/m ³)	71 (GPa)	310 (MPa)	276(MPa)	0.33
30CrMnSiA	7900(kg/m ³)	206 (GPa)	1080 (MPa)	835(MPa)	0.3

2. Cold extrusion

In order to obtain annular grooves on the specimen, the cold extrusion die was designed. The cold extrusion die is made of 30CrMnSiA. The main performance parameters of 30CrMnSiA are shown in Table 1.

The cold extrusion die is divided into an upper extrusion die and a lower extrusion die. Actual product is shown in figure 3. The two-dimensional drawing is shown in figure 3, and the. Use a depth gauge to measure the height of the annular punch of the upper extrusion die to be 0.33 mm, and the height of the annular punch of the lower extrusion die to be 0.34 mm.



Fig. 3. The cold extrusion die

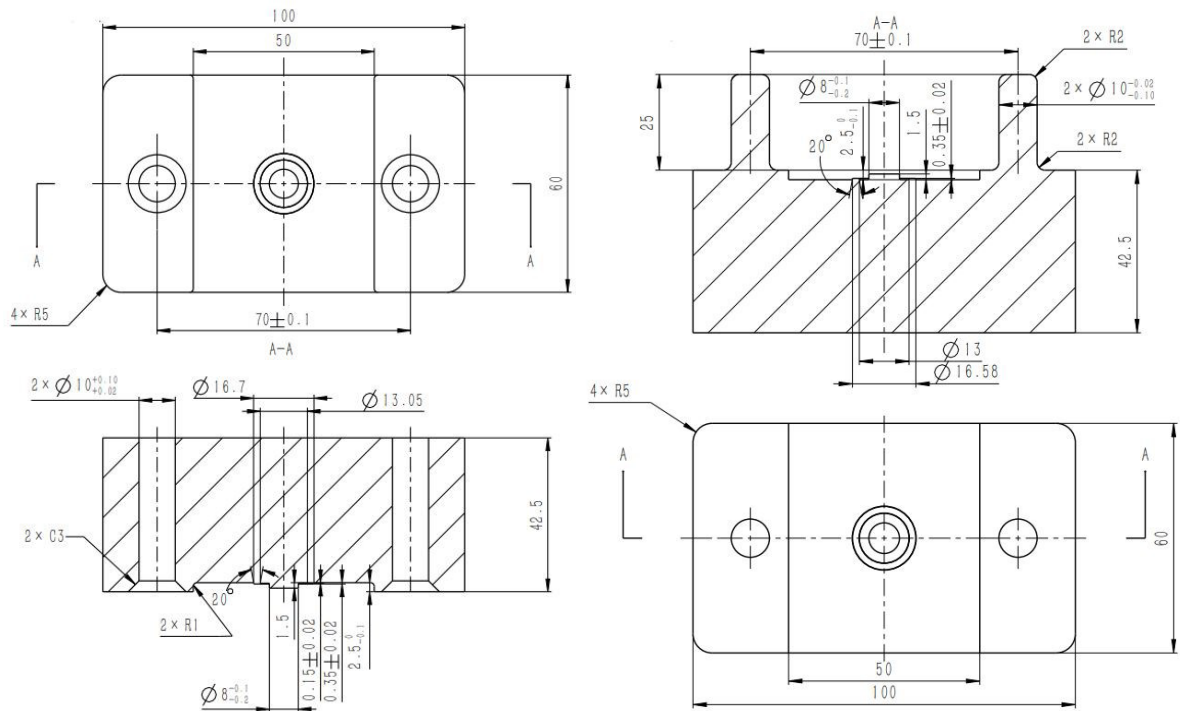

Fig. 4. Two-dimensional dimensional drawing of the cold extrusion die
 a) The upper extrusion die b) The lower extrusion die

The specimen extrusion equipment is the WANCE universal testing machine, which can output a maximum extrusion force of 1000 kN. The specimen extrusion site is shown in Figure 5.

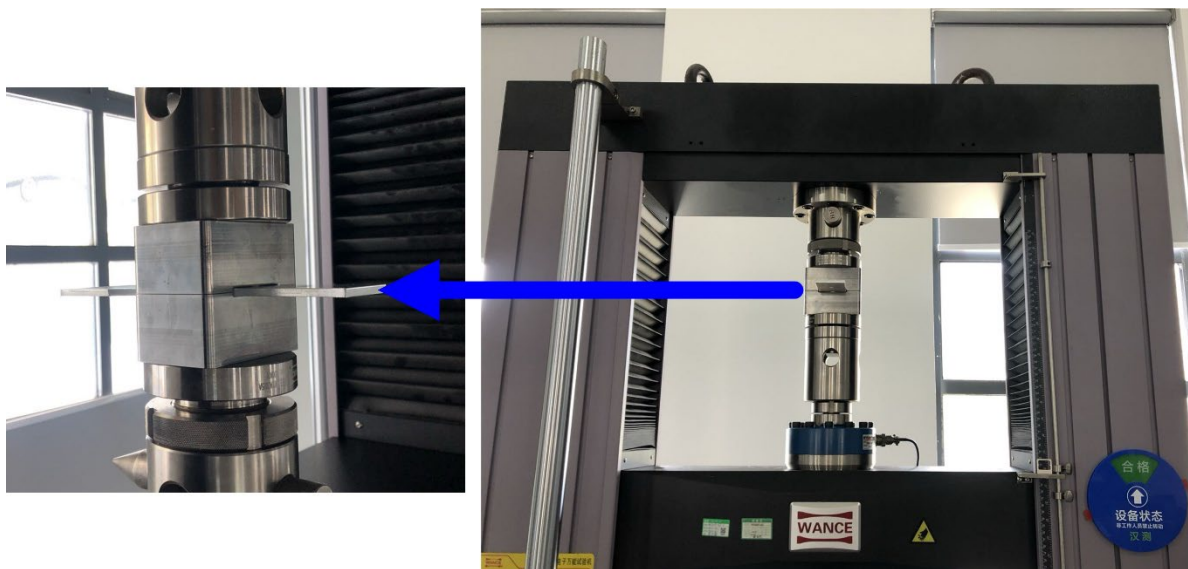

Fig. 5. WANCE universal testing machine

The test steps for extruding annular grooves on the specimen are as follows:
 1) Place the specimen in the groove between the upper extrusion die and the lower extrusion die, adjust any functional hole on the specimen to align with the positioning piles on the upper extrusion die and the lower extrusion die;

- 2) Place the extrusion die with the specimen installed in the center of the lower extrusion table, and adjust the upper extrusion table to contact the extrusion die;
- 3) Set the testing machine parameters: extrusion speed and extrusion force;
- 4) Click Start to extrude the specimen to obtain the extruded annular groove;
- 5) Remove the specimen from the cold extrusion die;
- 6) Repeat steps 1 – 5 to obtain the annular grooves corresponding to the other two functional holes on the specimen.

The upper and lower dies are squeezed by a universal testing machine to obtain a specimen with an annular groove in the extrusion test, as shown in Figure 6.

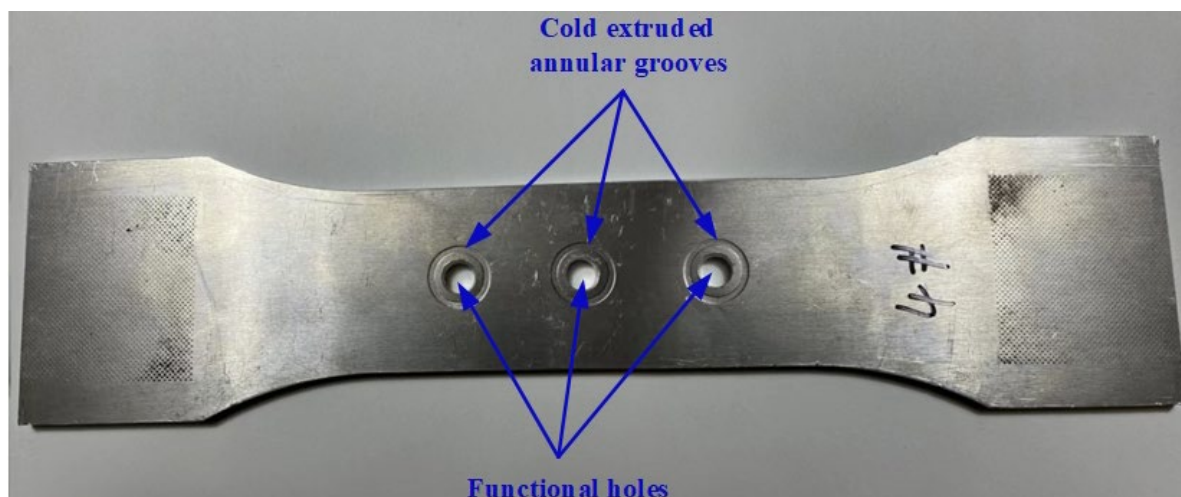

Fig. 6. Specimen with annular grooves

The specimens are extruded with extrusion forces of 0, 20 kN, 40 kN, 60 kN, 80 kN and 100 kN respectively. Use a depth gauge to measure the depth of the annular groove formed by extrusion of the specimen, as shown in Figure 7. Measure three different places and average the results to obtain the results in Table 2 below.



Fig. 7. Measuring the depth of the annular groove

Table 2

Annular groove depth of specimen

Working conditions	Specimen number	Extrusion speed (mm/min)	Squeeze force (kN)	Extrusion depth (mm)	Average extrusion depth (mm)
1	I-0-1, I-0-2, I-0-3, II-0-1, II-0-2, II-0-3	0	0	0	0
2	I -20-1, I -20-2, I -20-3 II -20-1, II -20-2, II -20-3	1	20	0.06/0.07/0.05	0.06
3	I -40-1, I -40-2, I -40-3 II -40-1, II -40-2, II -40-3	1	40	0.13/0.14/0.13	0.133
4	I -60-1, I -60-2, I -60-3 II -60-1, II -60-2, II -60-3	1	60	0.26/0.25/0.27	0.26
5	I -80-1, I -80-2, I -80-3 II -80-1, II -80-2, II -80-3	1	80	0.31/0.32/0.33	0.32
6	I -100-1, I -100-2, I -100-3 II -100-1, II -100-2, II -100-3	1	100	0.33/0.34/0.33	0.333

It can be seen from the results of the extrusion depth of the specimen that when the extrusion force is 0, 20 kN, 40 kN, and 60 kN, the extrusion depth increases linearly with the extrusion force. When the extrusion force is 80 kN or 100 kN, the extrusion depth of the specimen is close to the maximum height of the extrusion punch of the cold extrusion die, and the extrusion depth remains basically unchanged. However, the extrusion depth is slightly different due to the influence of extrusion force.

2. Fatigue test

During the test process, the test equipment used is the WANCE-100 model fatigue machine, as shown in Figure 8. The fatigue machine can be used to mechanically test metal samples, individual parts, through compression, tension, longitudinal and transverse bending under static and cyclic loading. During the test, different load forces are loaded on the specimen (the load on the wing component can be determined according to the simplified segmentation method [6-7]) for fatigue testing, the working frequency is 20 Hz, and 3 specimens are tested under each working condition.

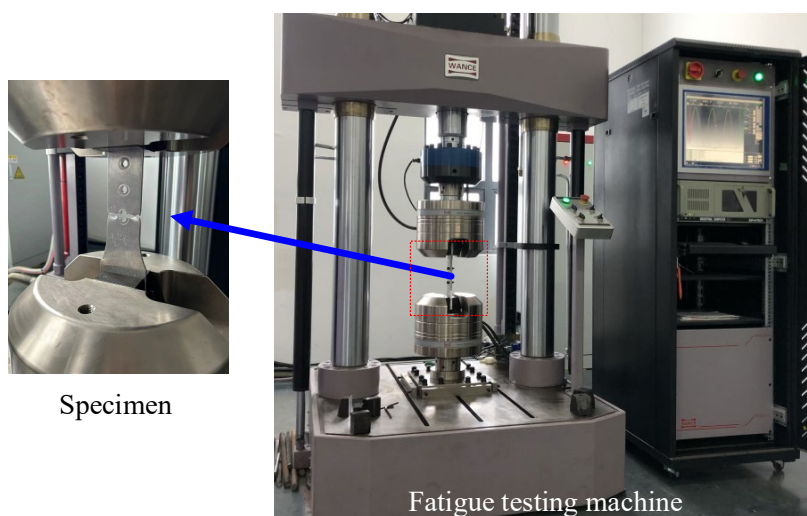

Fig. 8. WANCE-100 fatigue testing machine

Under different working conditions, the fatigue life results of the specimens are shown in Table 3, and the specimens after fatigue fracture are shown in Figure 9.

Table 3

Fatigue life of specimens

Working conditions	Specimen number	Working frequency, HZ	Loading force, kN	Fatigue life	Average fatigue life
I -1	I-0-1, I-0-2, I-0-3	20	80	5490/7408/21526	11474.7
I -2	I-20-1, I-20-2, I-20-3	20	80	19378/32771/27026	26391.7
I -3	I-40-1, I-40-2, I-40-3	20	80	137795/105450/70923	104722.7
I -4	I-60-1, I-60-2, I-60-3	20	80	379797/337384/415450	377543.7
I -5	I-80-1, I-80-2, I-80-3	20	80	189778/178839/144559	171058.7
I -6	I-100-1, I-100-2, I-100-3	20	80	176103/150050/115800	147317.7
II -1	II-0-1, II-0-2, II-0-3	20	100	6086/5233/7800	6373
II -2	II-20-1, II-20-2, II-20-3	20	100	10545/11200/12020	11255
II -3	II-40-1, II-40-2, II-40-3	20	100	11912/15506/13033	13483.7
II -4	II-60-1, II-60-2, II-60-3	20	100	12388/17578/14996	14987.3
II -5	II-80-1, II-80-2, II-80-3	20	100	7408/12300/11053	8033.7
II -6	II-100-1, II-100-2, II -100-3	20	100	7063/10360/9043	8822

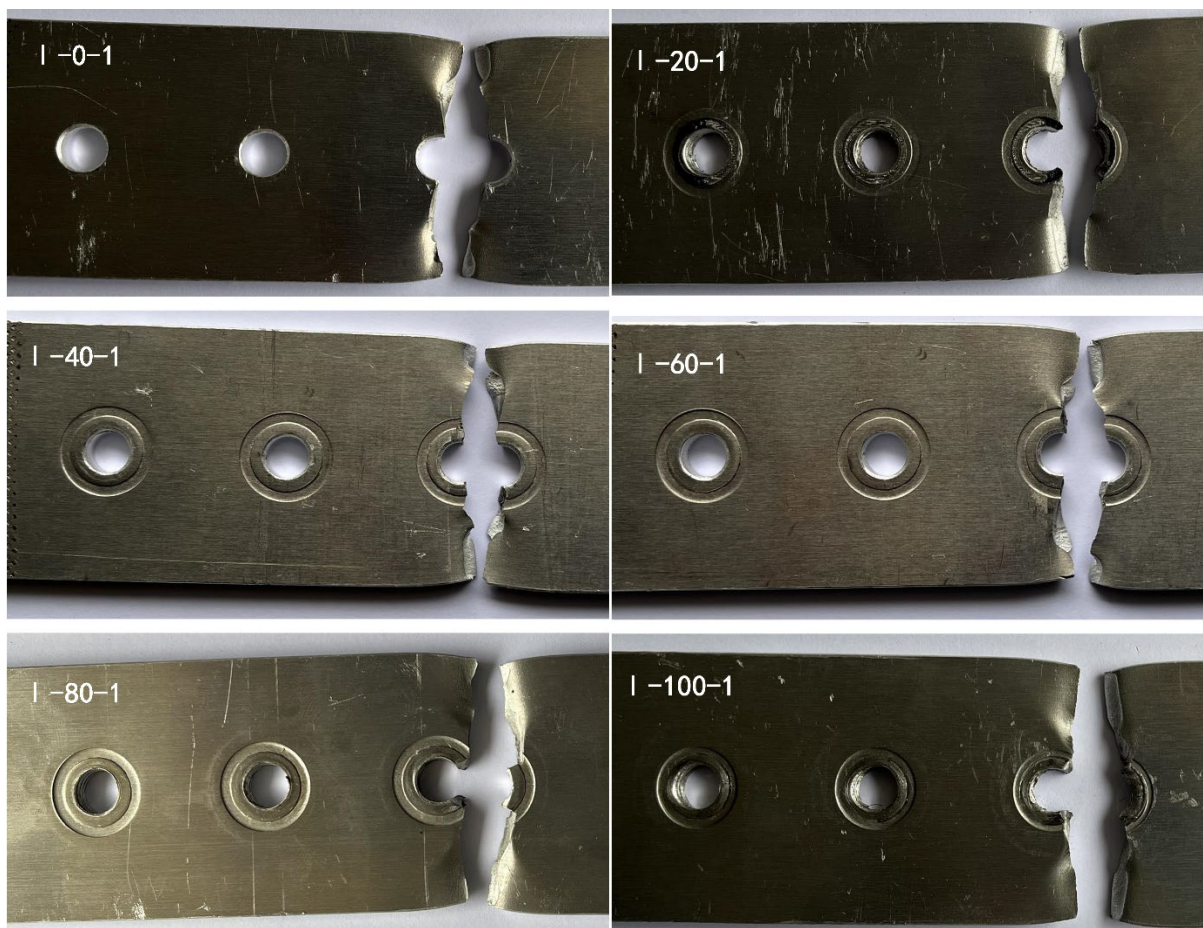

Fig. 9. Specimens after fatigue fracture

Through data processing, it can be obtained that the relationship between the extrusion depth and the fatigue life of the specimen under a load of 110 MPa in fig. 10.

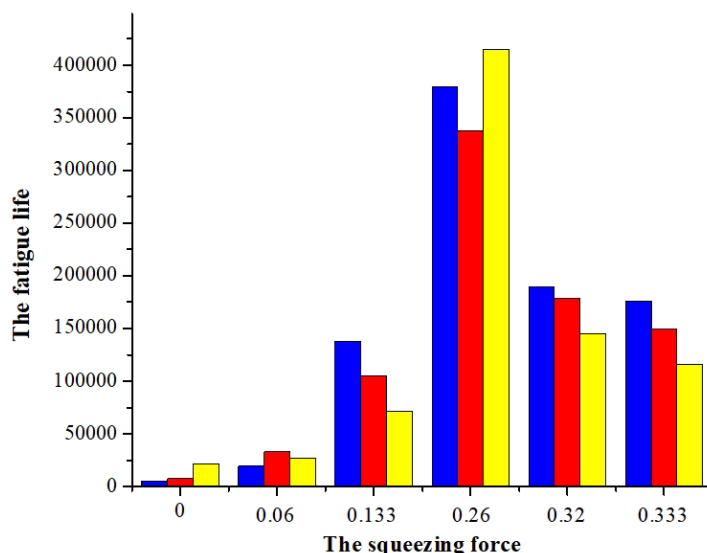

Fig. 10. The relationship between extrusion depth and specimen fatigue life under 110 MPa loading

The relationship between the extrusion depth and the fatigue life of the specimen under a load of 150 MPa is shown in Figure 11.

It can be seen from the results in Figures 10 and 11 that there are differences in the fatigue life of different specimens under the same working conditions. This is caused by factors such as differences in the material of the test piece itself, differences in the processing technology of the test piece, and differences in the trial extrusion process, which is a normal phenomenon. Therefore, the average fatigue life of three specimens is taken to eliminate the influence of these differences.

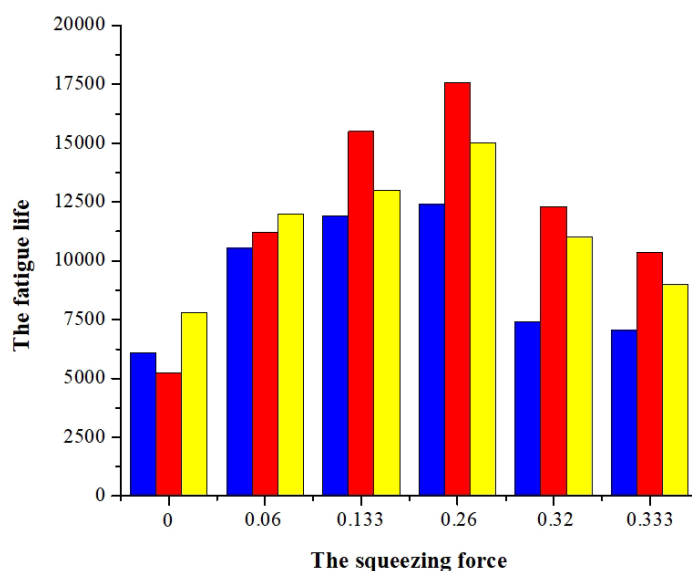

Fig. 11. The relationship between extrusion depth and specimen fatigue life under 150 MPa loading

Under different working conditions, the average fatigue life of the specimen is affected by the extrusion depth of the annular groove. The fatigue life of the specimen changes in an inverted "V" shape as the depth of the cold extrusion annular groove

increases. When the depth of the cold extrusion annular groove is 0.26 mm, the fatigue life of the specimen is the maximum, increasing the fatigue life by 2.35 to 32.9 times when specimen thickness is 5 mm.

3. Conclusion

1) 6061 aluminum alloy is a widely used aviation material. Fatigue tests on specimens made of 6061 aluminum alloy can well reflect the mechanical properties of aircraft wing panels.

2) For aircraft wing panels with functional holes, the fatigue life of the wing panels can be improved by cold extruding annular grooves around the functional holes.

3) The fatigue life of aircraft wing panels with functional holes is affected by the depth of the cold extrusion annular groove. The fatigue life of the wing panel changes in an inverted "V" shape as the depth of the cold extrusion annular groove increases. When the groove depth is 0.26mm, the fatigue life of aircraft wing panels with functional holes is maximum, increasing the fatigue life by 2.35 to 32.9 times when specimen thickness is 5 mm.

This method is simple to operate, easy to test, and has strong engineering application value.

References

1. Boguslayev, V. A. Scientific Grounds of Structural and Production Concepts to Provide Aircraft Life Time [Text] / V. A. Boguslaev, S. A. Bychkov, A. G. Grebenikov, N. I. Moskalenko, A. M. Gumennyi, E. T. Vasilevsky, A. P. Eeretin, V. F. Sementsov, V. A. Grebenikov, O. M. Stolyarchuk, etc. // Kharkiv: Nat. Aerospace Univ. "KhAI". – 2019. – 268 p.

2. Ge, E. Residual stress fields and fatigue life of cold expansion hole in titanium alloy TC4 / Ge E, Su H, Cheng Y, Fu Y, Xu J, Xiao R // China Mechanical Engineering. – 2015. – Vol. 26(7). – P. 971.

3. Wang, X. Numerical prediction and experimental verification of fatigue life of TC4 plate strengthened by cold expansion / WANG Xing, XU Wu, ZHANG Xiao-jing, ZHANG Li-na, HU Ben-run // Journal of ZheJiang University (Engineering Science). – 2017. – Vol. 51(8), – P. 1610 – 1618.

4. Kiva, D. S. Construction and technological methods of increasing the fatigue durability of the airplane planer structure elements in the area of functional holes / D. S. Kiva, G. A. Krivov, V. F. Sementsov // Kiev: Ukrniyat. – 2015, – 188 p.

5. Sun, Y. Analysis of Force Distribution of Four Rows of Bolts in Aircraft Fitting Joint / Sun Yifang, O. G. Grebenikov, Chenghu Li // International Journal of Aerospace Engineering. – 2021. – Vol. 2011, – P. 11. <https://doi.org/10.1155/2021/9962645>.

6. Sun, Y. Method of design calculating of the strength of the transverse joint of the panels of outer wing section and the center section of the transport aircraft / Sun Yifang, V. E. Vasilevskiy, O. O. Vendin, O. G Grebenikov // Open Information and Computer Integrated Technologies – Kharkiv: Nat. Aerospace Univ. "KhAI". – 2023. – Vol. 97. – P. 142 – 157. <https://doi.org/10.32620/oikit.2023.97.09>

7. Sun, Y. Analysis of the stress-strain state of components in the fitting joint of outer wing section and center section of transport aircraft / Sun Yifang, O. O. Vendin // Open Information and Computer Integrated Technologies – Kharkiv: Nat. Aerospace Univ "KhAI". – 2021. – Vol. 91, – P. 78 – 93. <https://doi.org/10.32620/oikit.2021.91.07>

Надійшла в редакцію 20.12.2023, розглянута на редколегії 20.12.2023

Вплив кільцевих канавок холодного обтиску на довговічність панелей крила з функціональними отворами

У статті детально досліджено метод холодного обтиску кільцевих канавок для вирішення проблеми подовження втомного ресурсу літака, що зменшує втомний ресурс панелей крила літака за рахунок функціональних отворів. Цей метод є дуже простою та ефективною технологією виготовлення проти втоми. Щоб імітувати різні панелі крила з функціональними отворами, експеримент призначений для обтиску зразка з різними зусиллями обтиску для отримання кільцевих канавок різної глибини. Випробування на втому проводять на зразках з кільцевими канавками. Результати випробувань показують, що: 1) кільцеві канавки холодного обтиску можуть подовжити термін служби панелей крила з функціональними отворами; 2) на довговічність панелей крила з функціональними отворами впливає глибина кільцевої канавки холодного обтиску. Втомна довговічність змінюється у формі перевернутої букви "V" зі збільшенням глибини кільцевої канавки холодного обтискання; 3) коли глибина кільцевої канавки холодного обтиску становить 0,26 мм, втомна довговічність зразка з отворами є максимальною, а втомна довговічність збільшується в 2,35~32,9 рази при товщині зразка 5 мм.

Key words: панель крила; функціональний отвір; холодне обтискання; кільцева канавка; експеримент; втома життя.

Відомості про авторів:

Sun Yifang – аспірант кафедри проектування літаків та вертольотів, Національний аерокосмічний університет «Харківський авіаційний інститут», Україна. Електронна пошта: yifang.sun@khai.edu ORCID: 0000-0001-8482-1540.

Вендін Олексій Олександрович – провідний інженер навчального центра CAD/CAM/CAE, Національний аерокосмічний університет «Харківський авіаційний інститут», Україна. Електронна пошта: o.vendyn@khai.edu ORCID: 0000-0002-7784-5998.

Гребеніков Олександр Григорович – доктор технічних наук, професор кафедри проектування літаків та вертольотів, Національний аерокосмічний університет «Харківський авіаційний інститут», Україна. Електронна пошта: agrebenikov@ukr.net ORCID: 0000-0002-1509-0665.

About the Authors:

Sun Yifang – Postgraduate Student, Aircraft and Helicopter Design Department, National Aerospace University "Kharkiv Aviation Institute", Ukraine. E-mail: yifang.sun@khai.edu ORCID: 0000-0001-8482-1540.

Oleksii Vendin – Leading engineer, Education Center CAD/CAM/CAE, National Aerospace University "Kharkiv Aviation Institute", Ukraine. E-mail: o.vendyn@khai.edu ORCID: 0000-0002-7784-5998.

Oleksandr Grebenikov – Dr. Tech. Sc., professor, Department Aircraft and Helicopter Design, National Aerospace University "Kharkiv Aviation Institute", Ukraine. E-mail: agrebenikov@ukr.net ORCID: 0000-0002-1509-0665.